

IAC Absorbatone™

A range of fabric covered acoustic absorption panels for reverberation control



Ideal for:

- Studios
- Hearing Test Rooms
- Meeting Rooms/
Lecture Rooms
- Theatres/Concert
Halls
- Restaurants
- Education
- Sports Halls



Why Absorbatone?

- BB93 compliant
- Cost effective solution
- Attractive finish
- Quick and easy installation
- Standard and bespoke sizes available
- Not susceptible to fibre migration
- Lightweight

Absorbatone™ is a range of fabric covered absorber panels specifically designed to reduce and control reverberation time.

Once fitted, Absorbatone™ panels create a pleasant acoustically enhanced environment and can greatly improve speech intelligibility.

Absorbatone™ is available in the following standard sizes, in thicknesses of either 25mm or 40mm:



300mm x 300mm
600mm x 600mm
600mm x 1000mm
600mm x 1200mm
1200mm x 1200mm
1200mm x 1500mm
1200mm x 2400mm

Panels can also be custom manufactured in any size up to 1200mm x 2400mm.

Weight

25mm thick: 3.5kgs per square metre
40mm thick: 4.5kgs per square metre

Finish

IAC Absorbatone™ panels are wrapped using acoustically transparent, highly durable fabrics which compliment the excellent sound absorbing properties of the interior.

A choice of colours ensures that Absorbatone panels can either be a feature or discretely blend into the background depending on the application and customers requirements.

Absorbatone™ is designed to be directly fixed to flat surfaces (walls/ceilings) with high tack adhesive and clip spikes or hung with supplied metal hooks and cable.

Acoustic Performance

IAC offer a full acoustical service to help determine the optimum solution for each project in terms of panel quantities required and location.

Absorbatone™ has been independently tested to ISO 354 and is classified according to ISO 11654.

40mm thick Panels	25mm thick Panels
Absorber Class: A	Absorber Class C
NRC: 0.95	NRC: 0.80

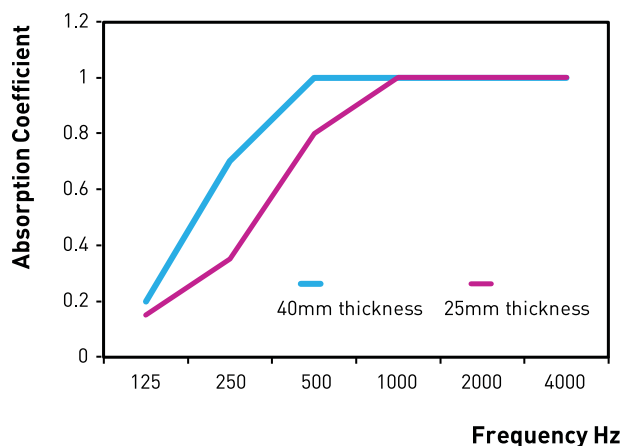

Fire Performance

The fabric finish meets the requirements of Class 1 Surface Spread of Flame when tested to BS 476: Part 7: 1987 while the fibreglass interior meets the Class 0 requirements of the building regulations when tested to BS476 Part 6 1981 and Part 7 1987. The composite panel has not been tested.

Packing

IAC Absorbatone™ panels will be delivered cardboard protected, shrink wrapped on a wooden pallet. Pallets are not to be stacked and should not be left outdoors.

Handling

Absorbatone should only be unpacked in clean/dry conditions and extra care should be taken when handling.



Panel Installation

Installing Absorbatone panels directly to walls and ceilings is simple using the adhesive sealant which will be supplied with each order. Absorbatone panels can be directly installed to any internal wall surface including brick, concrete, wood, plaster or metal.

Surface Preparation

The wall or ceiling must be clean and dry prior to installing Absorbatone panels and be free from dust, oil / grease and loose paint / plaster. Where possible, wallpaper should be removed and gloss paint roughened. Absorbent surfaces such as brick should also be applied with some of the adhesive sealant provided for additional strength.

Fixing Panels

The final position of panels should be marked out on the mounting surface prior to installation then suitably and securely fix the clips and screws. The reverse side of the panels should be coated as per the diagram below with the adhesive sealant. When using the adhesive, do so in a well ventilated area and at room temperature.

Once the adhesive has been applied, carefully position the panel. Fit one of the corners first and align vertically and horizontally applying an even pressure over the panel so that the clips bite into the panel.

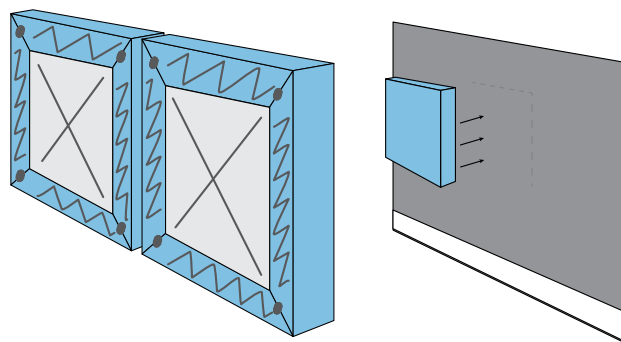

Cleaning

Absorbatone panels can be periodically cleaned with a vacuum cleaner to remove dust. Under no circumstances should water be applied to the surface of the panels, as this may cause staining of the fabric covering. Should the panels become marked or stained, sometimes a non-solvent based cleaning solution can be applied, however it is recommended that a test is carried on a small area first.



**Head Office - Winchester, UK****T:** +44 (0) 1962 873 000**E:** info@iac-uk.com**Australia****T:** +61 (0) 2 8781 0400**F:** +61 (0) 2 9725 2939**E:** info@iac-australia.com.au**China (Dongguan Office)****T:** +86 (0) 769 89899966 802**F:** +86 (0) 769 89899966 810**E:** china.sales@iac-china.com**China (SH Office)****T:** +86 (0) 21 68825328**E:** test@iac-china.com**Denmark****T:** +45 36 77 88 00**E:** mail@iac-nordic.dk**Germany****T:** +49 (0) 2163 9991 0**F:** +49 (0) 2163 9991 23**E:** deutschland@iac-gmbh.de**Ireland****T:** +353 1 282 8043**F:** +353 1 282 8427**E:** ireland.info@iac-noisecontrol.com**Israel****T:** +972 894 284 83**F:** +972 894 284 86**E:** hna.info@iac-noisecontrol.com**Italy****T:** +39 0445 575 669**F:** +39 0445 575 002**E:** italy.info@iac-noisecontrol.com**Kuwait****T:** +965 2294 2000**E:** kuwait.info@iac-noisecontrol.com**United Arab Emirates****T:** +971 (0) 4451 7877**E:** uae.info@iac-noisecontrol.com